

# 635 nm CS-mounted high-power laser bar

ML1806

modulight  
on your wavelength

## OVERVIEW

ML1806 is a CS-mounted laser bar (laser array) producing up to 7 W of output power. The product is designed for CW operation at 635 nm, providing very good power conversion efficiency. For the unmounted version of this laser, please refer to product ML1515.



## APPLICATIONS

Medical  
Imaging

Laser display  
Illumination

## ELECTRO-OPTICAL CHARACTERISTICS

Parameter	Symbol	Typical value	Unit
Threshold Current	$I_{TH}$	8	A
Optical Output Power	$P_{OPT}$	7	W
Operating Current	$I_{OP}$	15	A
Operating Voltage	$V_{OP}$	< 2.5	V
Slope Efficiency	$\eta$	0.9	W/A
Peak Wavelength	$\lambda$	$633 \pm 3$	nm
Wavelength Temperature Coefficient	$\Delta\lambda/\Delta T$	0.2	nm/K
Spectral Width	$\delta\lambda$	1.2	nm
Parallel Beam Divergence (FWHM)	$\theta_{  }$	3	°
Perpendicular Beam Divergence (FWHM)	$\theta_{\perp}$	38	°

All above values are typical for CW operation @ 15°C

## ABSOLUTE MAXIMUM RATINGS

Parameter	Symbol	Rating	Unit
LD reverse voltage	$V_{RLD}$	0	V
LD forward current	$I_{FLD}$	16	A
Operating temperature range <sup>1</sup>	$T_{OP}$	5...20	°C

<sup>1</sup> A non-condensing environment is required when operating below the dew point.

## MECHANICAL SPECIFICATIONS

Parameter	Symbol	Value	Unit
Fill Factor	FF	20	%
Emitters in a Bar		19	

# 635 nm CS-mounted high-power laser bar

ML1806

**modulight**  
on your wavelength

## PACKAGE INFORMATION

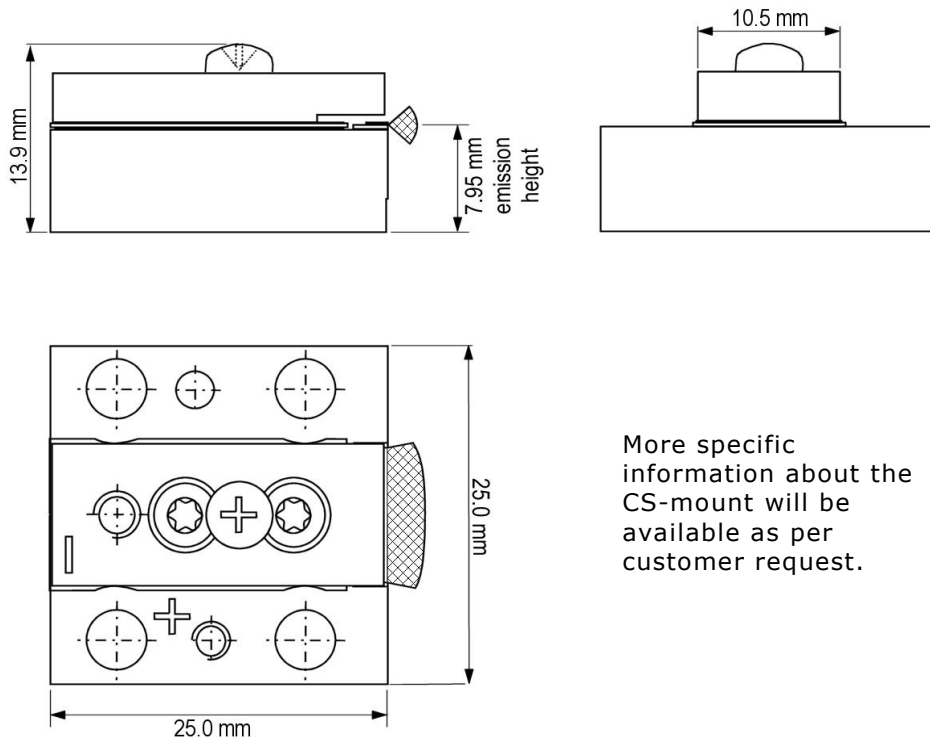

More specific information about the CS-mount will be available as per customer request.

## SAFETY INFORMATION

- The laser light emitted from this laser diode, although visible, is harmful to the human eye. Avoid eye and skin exposure to the beam, both direct and reflected.
- Products are subject to the risks normally associated with sensitive electronic devices including static discharge, transients, and overload. Please ensure ESD protection prior to handling the products.
- These Modulight products are not intended for use in systems where product malfunction can reasonably be expected to result in personal injury.



Peak power and wavelength are for safety analysis only, not to present device performance.

## LIABILITY NOTE

- This document is sole property of Modulight, Inc. No part of this document may be copied without written acceptance of Modulight, Inc.
- All statements related to the products herein are believed to be reliable and accurate. However, the accuracy is not guaranteed and no responsibility is assumed for any inaccuracies or omissions. Modulight, Inc. reserves the right to make changes in the specifications at any time without prior notice.