

ML1470

1550 nm, 400 mW high-power laser in 9 mm TO-can

Overview

A part of Modulight's RangerLase product family, ML1470 is a high-performance multi-mode 1550 nm laser designed for applications requiring high-power laser radiation at eye-safe wavelengths. The laser is housed in a 9-mm TO-can (SOT-148) covered by a flat window. The laser device is designed to withstand CW operation. Due to the inherent thermal sensitivity of this laser product, proper cooling must be ensured during operation.



Applications

Defense	Industrial	Medical
Eye-safe range-finding Illumination	Materials processing Optical pumping	Low-intensity laser therapy Aesthetic Treatments

Electro-optical Characteristics

Parameter	Symbol	Typical value	Unit
Peak Wavelength	λ	1560 ± 20	nm
Optical Output Power (peak power)	P_{OPT}	400	mW
Operating Current	I_{OP}	2	A
Operating Voltage	V_{OP}	1.8	V
Slope Efficiency	η	> 0.28	W/A
Threshold Current	I_{TH}	< 0.7	A
Wavelength Temperature Coefficient	$\Delta\lambda/\Delta T$	0.6	nm/K
Spectral Width	$\delta\lambda$	9	nm
Parallel Beam Divergence (FWHM)	$\theta_{ }$	7	°
Perpendicular Beam Divergence (FWHM)	θ_{\perp}	33	°
Emitter Width	W_E	100	μm

All values are typical for CW operation @ 20°C.

Absolute Maximum Ratings

Parameter	Symbol	Rating	Unit
LD Reverse Voltage	V_{RLD}	2	V
LD Forward Current	I_{FLD}	3.5	A
Operating Temperature	T_{OP}	0...30 ¹	°C
Storage Temperature	T_{STG}	-40...85	°C

¹ A non-condensing environment should be ensured over the useful temperature range.

Package Information

The default package of the red lasers is a 9 mm TO-can package (SOT-148). The most important dimensions are shown in the drawing below. Monitor photodiode and collimation optics can be included in all the 9 mm TO-can packages per customer request - please contact Modulight sales team for more information.

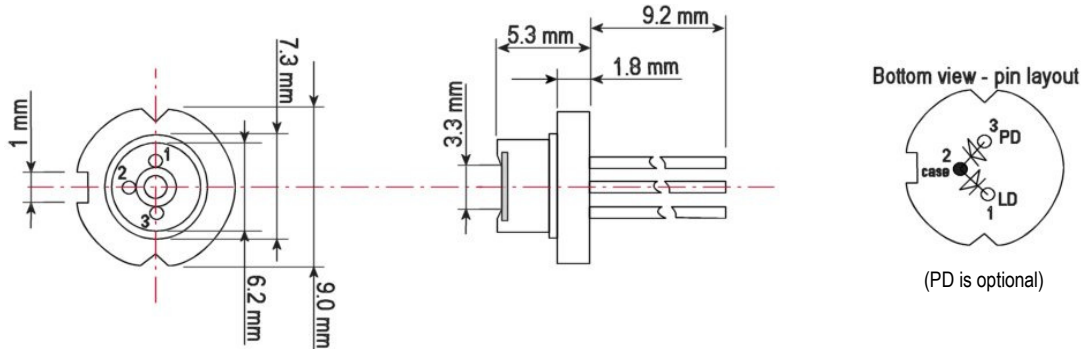

Safety Information

- The laser light emitted from this laser diode is invisible and harmful to the human eye. Avoid eye and skin exposure to the beam, both direct and reflected.
- Products are subject to the risks normally associated with sensitive electronic devices including static discharge, transients, and overload. Please ensure ESD protection prior to handling the products.
- These Modulight products are not intended for use in systems where product malfunction can reasonably be expected to result in personal injury.

DANGER

INVISIBLE LASER RADIATION
AVOID EYE OR SKIN EXPOSURE TO
DIRECT OR SCATTERED BEAM

Peak power:	1.5 W
Wavelength:	1550 nm
Class 4 laser product	

Peak power and wavelength are for safety analysis only, not to present device performance.

Liability note

This document is sole property of Modulight, Inc. No part of this document may be copied without written acceptance of Modulight, Inc. All statements related to the products herein are believed to be reliable and accurate. However, the accuracy is not guaranteed and no responsibility is assumed for any inaccuracies or omissions. Modulight, Inc. reserves the right to make changes in the specifications at any time without prior notice.